

Smart Grid Fault Diagnosis, Positioning Method and Monitoring System Based on Wireless Sensor Network

Zhijie Li^{1,*} and Jincheng Hu^{2,†}

¹*School of Computers and Design, Guangdong Mechanical & Electrical Polytechnic, Guangzhou 510550, Guangdong, China*

²*School of Information Management & Engineering, Shanghai University of Finance and Economics, Shanghai 200433, China*

Information technology has undergone a great deal of development in response to the needs of individuals, communities, government bodies, and industry. A major development in recent years has been the wireless sensor network (WSN) which is a significant milestone in the development of information technology and an important indicator of the progress that has been made in the fields of science and technology. Wireless sensor networks now play a major role in areas such as the military, environmental development monitoring, biological research and medical system construction, disaster monitoring, and energy allocation. The development and management of smart grid are related to people's daily lives and production activities. In order to improve the efficiency of smart grid management, in this paper, a monitoring system is designed for the prevention of grid failures based on the analysis of the construction of wireless sensor networks. Prior to designing the monitoring system, this study also examined the fault situation of the smart grid. The system proposed in this study can accurately determine the location of the fault. This study also verified the feasibility of the monitoring system through experiments, and analyzed the accuracy of the monitoring system in determining where the fault occurred.

Keywords: wireless sensor network; smart grid; fault diagnosis; monitoring system

1. INTRODUCTION

In recent years, the construction of wireless sensor networks represents another milestone in the development of information technology, indicating the strides made in science and technology. Wireless sensor networks have been implemented in many fields in China including the military, environmental development monitoring, biological research and construction of medical systems, disaster monitoring, and energy allocation. The analysis of the utilization of spectrum resources in the traditional communication environment has

shown that in the traditional communication process, the government has stipulated and divided the use range of spectrum resources [1]. The development and management of smart grid are related to people's daily lives and production activities. In order to improve the efficiency of smart grid management, in this paper, a monitoring system is designed for grid failures based on the analysis of the construction of wireless sensor networks. The technology involved in the operation of wireless sensor networks, and the specific issue of smart grid fault maintenance, are examined. The aim of this research is to improve the smart level of the power grid by studying the setting of wireless sensor network routing nodes and the time synchronization processing of sensors [2]. The research also conducted a simulation of the designed monitoring system by constructing mathematical models and

*2006010012@gdmec.edu.cn

†Address for correspondence: School of Information Management & Engineering, Shanghai University of Finance and Economics, Shanghai 200433, China. Email: hujincheng8888@126.com

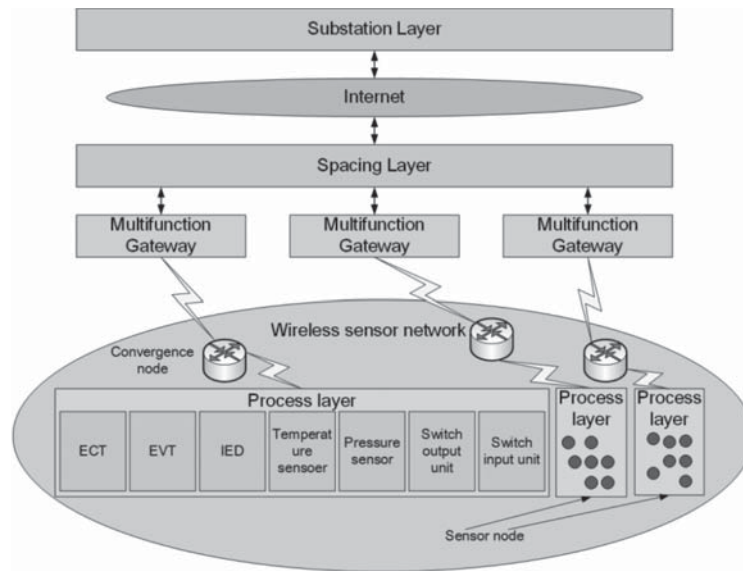

Figure 1 WSN networking scheme of substation.

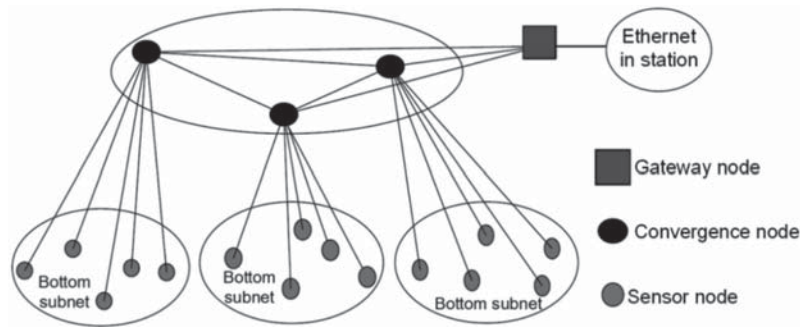

Figure 2 Wireless sensor network structure of substation.

applying related algorithms, and effectively analyzed the system’s operation.

1.1 Application of Wireless Sensor Network in Smart Substation

Multiple sensor nodes are used in the construction of a wireless sensor network. Although the data transmission capacity of each sensor node is different, the nodes together form the entire wireless sensor network. Because of the node characteristics of the sensor, the node in the middle of the system can perform the fusion of the system’s data or can forward the data. Although wireless sensor networks have many advantages, they are also affected by many factors [3]. For instance, the energy management of the wireless sensor network and the storage capacity of the system are the main factors that restrict the operation of the network system. Moreover, there are many other factors that make the operation of the wireless sensor network not particularly stable. Therefore, the current operation protocol for the wireless network needs to be changed to ensure the efficient operation of the WSN.

During the construction of the substation, various advanced digital devices such as electronic transformers and smart

circuit breakers together form a wireless sensor network for substation management. The development of the wireless sensor network in the communication grid module can change the mode of the original system interface, and the radio frequency identification technology used by the wireless sensor can produce a wireless communication link, which can replace the current wired connection [4]. In the network, the connection between the process layer and the bay layer needs to be achieved by the trip command of the system. The WSN scheme of the substation is shown below in Figure 1.

Figure 2 shows that smart substations are layered by means of a distributed communication structure, and the construction of a WSN substation involves a two-layer topology structure to establish network connections. Since the government has imposed strict regulations regarding the direction and usage of spectrum resources, users cannot change the content of spectrum resources when they use these for communication, and some spectrum resources may be put on hold and cause wastage [5]. The spectrum resources authorized by the government are basically allocated by the primary user, and the efficiency of spectrum resources utilization is not particularly high, with some unlicensed spectrum resources being placed under great pressure. Many technologies use these frequency bands to communicate and exchange resources, but these spectrum resources have not been authorized, and it is difficult to quickly establish communication links between frequency

bands [6], possibly leading to congestion, delays and packet loss during transmission.

1.2 Related Concepts of Node Positioning

1.2.1 Anchor Node

In a WSN, a node that can determine its own location and can also indicate the location of other nodes, is known as an anchor node. This type of node can be either static or dynamic [7], and can determine its own location information through a positioning device in the system or one arranged by the user.

1.2.2 Unknown Node

In a WSN, the location of some nodes cannot be determined, and the existence of a node can be determined only by analyzing the location information. This kind of node is an unknown node. The location of the unknown node needs to be determined by the location information provided by the anchor node.

1.2.3 Reference Node

When determining the location of an unknown node, the location information provided by the anchor node is used to establish a geometric constraint equation or a distance judgment equation, and the specific coordinates of the location node can be obtained through specific calculations [8]. The parameters for the calculations, and the anchor nodes that help unknown nodes make position judgments, are known as parameter nodes. Normally, the various unknown nodes have corresponding parameter nodes.

1.2.4 Hops

The number of hops between two nodes is the number of hops between two nodes. If three nodes are adjacent to each other in pairs, then the hops of the first node and the third node are 2, and the hops of other nodes. The situation can also be judged according to this rule.

1.2.5 Connectivity

Connectivity is the degree of connection between each individual node and other nodes. If it is the connectivity of a single node, it mainly represents the number of neighbor nodes around this node [9]. Assuming that there are multiple nodes distributed in a region, the number of nodes around a single node can be expressed as:

$$\mu(R) = (N\pi R^2)/A \quad (1)$$

1.2.6 Relative Error of Single Node Positioning

$$error = \|r_{est} - r_{real}\|/R \times 100\% \quad (2)$$

1.2.7 Total Average Relative Error

$$error = \sum_{i=m+1}^n \|r_{est}^i - r_{real}^i\|/(n-m)R \times 100\% \quad (3)$$

1.3 Basic Principles of Wireless Sensor Network Positioning

Usually, a specific technology or calculation method is applied to determine the location of a node in a WSN. After determining the location and number of anchor nodes in the WSN, one or more positioning technologies can be used to find the locations of unknown points. If there is no anchor node in the wireless sensor network, the specific position of each node cannot be accurately determined, and the relative positions of nodes can only be estimated based on their characteristics. The positioning problems in this study are all analyzed in a two-dimensional space [10]. The positioning algorithms used are all based on the characteristics of the location changes of nodes in the WSN and the distance between each node to determine the specific location of a node. Judgment and estimation. By analyzing the above characteristics to determine the specific location of the node, the existing location information and data can be adjusted, and the accuracy of system positioning can be improved. In order to enable the existing spectrum resources to be effectively used, and to promote the development of radio communication technology, many related scholars have conducted comprehensive researches, and finally combined radio communication technology with wireless sensing technology, creating the new cognitive Wireless Sensor Network [11]. The environmental energy-saving monitoring IoT system can perceive the environment where the user's device is located, analyze climatic conditions such as temperature and humidity, and find the frequency band hole access generated when the user's device is not communicating, so as to avoid any interference when the user is communicating. The environmental energy-saving monitoring IoT system has a new frequency band resource management function. It can receive and discover real-time frequency band holes, and use dynamic spectrum communication technology to access, which can increase the speed of communication [12]. The environmental energy-saving monitoring IoT system While accessing holes in real time, it also adjusts the system's own software and hardware configuration according to the frequency band, so that even in a more crowded frequency band, the user can make full use of frequency band resources, prevent communication interference, and improve communication speed and spectrum efficiency.

1.4 Application of Wireless Sensor Network Positioning Algorithm in Smart Grid

To better apply the wireless sensor network in the construction of the transmission line of the smart grid, the location of the sensor nodes needs to be arranged artificially, and the sensor nodes cannot be randomly distributed. The layout of sensor nodes is:

$$A = \{a_1, a_2, \dots, a_i, i = 1, 2, \dots, n\} \quad (4)$$

$$B = \{b_1, b_2, \dots, b_i, i = 1, 2, \dots, n\} \quad (5)$$

$$C = \{c_1, c_2, \dots, c_i, i = 1, 2, \dots, n\} \quad (6)$$

If the distance between the three transmission lines is k , then the distance between the sensor nodes is also k .

$$\begin{aligned} d(a_i, a_{i+1}) &= d(a_{i+1}, a_{i+2}) = d(b_i, b_{i+1}) \\ &= d(b_{i+1}, b_{i+2}) = d(c_i, c_{i+1}) = d(c_{i+1}, c_{i+2}) \end{aligned} \quad (7)$$

By analyzing the situation of any node, it is clear that the radius of the dotted circle is the communication range of the node. As long as the node is within the communication range, the following formula can be used to find the set of hops in the communication network:

$$S_{b_3} = \{a_2, a_3, a_4, b_2, b_4, c_2, c_3, c_4\} \quad (8)$$

The distance from any node b_3 to other nodes can be expressed as:

$$\begin{cases} d_{a_1} = \sqrt{K^2 + k^2} \\ d_{b_1} = K \\ d_{b_6} = K \end{cases} \quad (9)$$

The distance from this arbitrary node to the anchor node can be obtained with:

$$\begin{cases} D_{a_1} = (2 - 1) \times K + \sqrt{K^2 + k^2} \\ \quad = K + \sqrt{K^2 + k^2} \\ D_{b_1} = (2 - 1) \times K + K = 2K \\ D_{b_6} = (3 - 1) \times K + K = 3K \end{cases} \quad (10)$$

2. DESIGN AND IMPLEMENTATION OF A SMART GRID FAULT MONITORING SYSTEM BASED ON WIRELESS SENSOR NETWORKS

2.1 The Overall Structure of the System

2.1.1 Wireless Sensor

During the construction of the wireless sensor network, different sensors will monitor the operation of the smart grid. The voltage and current transmitted by the grid and the circuit, and the change in the temperature and humidity in the environment, are all indicators that the sensors need to monitor [13]. The wireless sensor can adjust and arrange the monitoring area of the smart grid according to the location information of the node, and transmit the data generated during the operation of the circuit to the control center of the smart network, so that the control center can coordinate the related content of the circuit transportation. Through coordination and data analysis, people can monitor the operation of the smart grid in real time.

2.1.2 Gateway

The power grid monitoring system of the wireless sensor network designed in this paper is dependent on the collection and processing of circuit transportation parameter information to realize the practical application of related functions in the specific operation process. When the system is in effect, the body area network will collect and process the parameter

information of circuit transportation [14]. After unified processing, the body area network will transmit the parameter information of circuit transportation to the local gateway. After receiving the parameter information, the local gateway parses the parameter information according to actual analysis needs, converts the format of the parameter information to a certain extent, and transmits the converted physiological parameter information to the control center [15]. After the control center receives the converted parameter information, it will conduct a preliminary evaluation and inspection of the parameter information.

2.1.3 Server

The server is the core part of the smart grid monitoring system. The quality of the server is directly related to the stability and security of the monitoring system. The data in the server comprises both upstream and downstream data [16]. The upstream data is filtered by the network system according to the information provided by the coordinator, and the downstream data is the command issued by the system's data transmission function. The control of network data operation can be realized by transmitting the downstream data.

2.1.4 Client

The 'client' could be a computer, a mobile phone, or a PC. The client can connect the remote monitoring system and the server, and transmit the control commands of the remote monitoring system to the server, so that the server can be based on the remote system.

2.2 System Function Module Design

2.2.1 Single Node System

The hardware components of the system are shown in Figure 3 below.

2.2.2 Network System

The structure of the wireless sensor network consists of three main parts: the setting situation of the management node, the setting situation of the aggregation node, and the setting situation of the sensor node. During the construction of a traditional wireless sensor network, once the sensor detects some emergency information, it will generate a great deal of data within a short period of time. Such unexpected events will cause a certain amount of system operation [17]. The communication is blocked and cannot return quickly to normal. If the cognitive radio technology is introduced during the construction of the network platform, the information congestion problem caused by emergencies can be effectively alleviated, and the efficiency of information transmission and network operations can be improved. When establishing a wireless network, self-organization can be used to determine the location of sensor nodes, and it is necessary to ensure that the operating range of the network is within the fault monitoring range of the smart grid. The wireless sensor

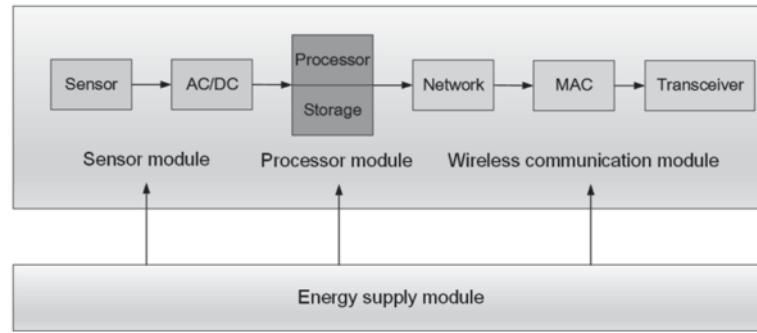

Figure 3 The hardware composition of the system.

Table 1 Comparative analysis of communication technology.

	wifi	Bluetooth	ZigBee
Frequency band	2.3GHz	2.3GHz	2.4GHz
Battery life/m	0.6–6	1–6	100–1000
Transmission distance/cm	1–60	1–20	1–100
Disadvantage	Power consumption	Short distance	Low rate
Advantage	High efficiency	Plug and play	Low cost, large capacity, plug and play

Table 2 Terminal equipment communication type and length.

	Transmission data type	Renewal cycle	Information unit length (bytes)
State quantity	Smart grid switch position, local	1–5 second polling cycle	1–3
	Switch energy storage for smart grid	1–5 second polling cycle	
	Terminal status and communication status	1–5 second polling cycle	1–3
	Smart grid fault signals and abnormal signals	1–5 second polling cycle	1–3

network can transmit the data collected by the fault monitoring network, and multiple nodes in the network will process the data and, finally, obtain aggregated data.

2.2.3 Communication Technology

Nowadays, it is possible for people to access information through an ever-increasing number of channels. In order to further improve the effectiveness of information transmission and energy transportation, more effective communication networks are being designed, with communication technology providing users with broader information transmission channels and space. When building a communication network, various factors are uncertain, which makes certain tasks more difficult [18] as well as requiring much time and cost; hence, it is vital that the communication network operates safely. Advanced communication technology can be applied to separate the communication connection of the wireless sensor network from the specific application equipment, and can establish a wireless communication connection with the failed network node. The application of communication technology to faulty grid nodes through wireless sensor networks can reduce the power of the system. The more widely-used communication technologies include wireless network, Bluetooth communication and Zigbee technology. In this study, these three communication technologies were examined, analyzed and compared. The results of the comparative analysis are given in Table 1 below.

2.3 System Software Design

In order to improve the feasibility of smart grid system monitoring, it is necessary to analyze the software operation of the designed smart fault monitoring system. In this study, the communication type and length of the monitoring equipment are analyzed. The analysis results are shown below in Table 2.

There are three main types of communication data indicators for smart grids. The specific conditions are shown below in Table 3.

2.4 System Test and Result Analysis

The fault monitoring system involved in this research is carried out using a PC for specific experiments and simulation analysis. The results of the experimental analysis are shown in Table 4 below.

3. CONCLUSION

The development of wireless sensor network has provided help for the development of many fields in our country. It plays an important role in the military field, environmental development monitoring field, biological research and medical system construction field, disaster monitoring field, and energy allocation. The development and management of smart grid are related to people’s daily life and production

Table 3 Communication data indicators for smart grid.

Communication type	Content	Data index
Real-time operation	Remote protection power system control	Fault information $\leq 80\text{ms}$ Measurement information $\leq 18\text{s}$ Circuit breaker action information $\leq 3\text{s}$
Management operations	Time Interference Recording Plan Information Processing	No need for real-time communication
Management	Asset management sub-station supervision	No need for real-time communication

Table 4 Smart grid fault monitoring.

Monitoring times/time	The failure of the smart grid		
	Suggest a way	Literature [4] method	Literature [5] method
1	20	8	10
2	20	8	11
3	20	10	15
4	20	12	16
5	20	15	16

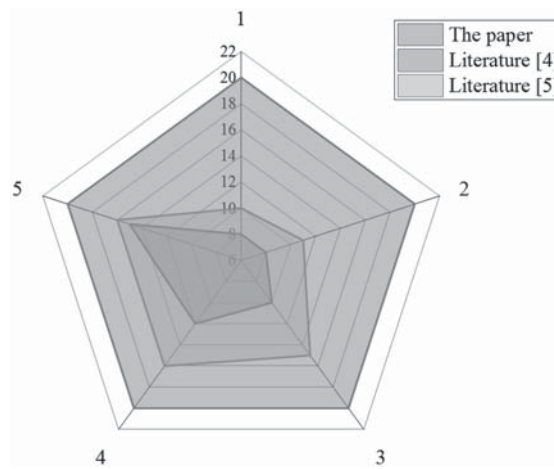

Figure 4 Comparison of the results of monitoring experiments for smart grid faults.

activities. In order to improve the efficiency of smart grid management, this article designs a monitoring system for grid failures based on the analysis of the construction of wireless sensor networks. Due to the influence of many factors, the operation of the wireless sensor network is not particularly stable. Therefore, the current network operation protocol of the wireless network needs to be changed to provide effective assistance for the operation of the wireless sensor network. This article analyzes the main technology involved in wireless sensor network operation, with specific reference to smart grid fault maintenance, and improves the smart level of the power grid by studying the setting of wireless sensor network routing nodes and the time synchronization processing of sensors.

REFERENCES

1. X. Luo, Y. Xia, Q. Zhu. Applying the learning rate adaptation to the matrix factorization based collaborative filtering. *Knowl Based Syst* 37(3) (2013), 154–164.
2. P. Massa, P. Avesani. Controversial users demand local trust metrics: an experimental study on Epinions.com community. In: *Proceedings of the 20th National Conference on*

- Artificial Intelligence (AAAI '05), vol 1. AAAI Press (2005), 121–126.
3. T. Neammanee, S. Maneeroj. Time-aware recommendation based on user preference driven. In: *2018 IEEE 42nd Annual Computer Software and Applications Conference (COMPSAC)*, Tokyo 10(9) (2018), 26–31.
4. F. Ortega, A. Hernando, J. Bobadilla, JH. Kang. Recommending items to group of users using matrix factorization based collaborative filtering. *Inf Sci* 345 (2016), 313–324.
5. M. Papagelis, D. Plexousakis, T. Kutsuras. Alleviating the sparsity problem of collaborative filtering using trust inferences. In: Herrmann P, Issarny V, Shiu S (eds) *Trust Management*. Springer, Berlin Heidelberg, Berlin, Heidelberg 47(6) (2005), 224–239.
6. H. Parvin, P. Moradi, S. Esmaili. TCFACO: trust-aware collaborative filtering method based on ant colony optimization. *Expert Syst Appl* 118 (2019), 152–168.
7. N. Polatidis, CK. Georgiadis. A multi-level collaborative filtering method that improves recommendations. *Expert Syst Appl* 48(5) (2016), 100–110.
8. L. Qi, R. Wang, C. Hu, et al. Time-aware distributed service recommendation with privacy-preservation. *Inf Sci* 480 (2019), 354–364.
9. L. Ren, W. Wang. An SVM-based collaborative filtering approach for Top-N web services recommendation. *Future Gener Comput Syst* 78(8) (2018), 531–543.

10. F. Rezaeimehr, P. Moradi, S. Ahmadian, et al. Tcars: time- and community-aware recommendation system. *Future Gener Comput Syst* 78(3) (2018), 419–429.
11. A. Stuart, Rank correlation methods (By M. G. Kendall, 2nd edn). *Br J Stat Psychol* 9(1) (1956), 68–68.
12. G. Tian, J. Wang, K. He, et al. Integrating implicit feedbacks for time-aware web service recommendations. *Inf Syst Front* 19(1) (2017), 75–89.
13. Y. Wang, M.P. Singh. Formal trust model for multiagent systems. In: *Proceedings of the 20th International Joint Conference on Artificial Intelligence (IJCAI'07)*. Morgan Kaufmann Publishers Inc., San Francisco, CA, USA 57(5) (2007), 1551–1556.
14. X. Wang, J. Zhu, Z. Zheng, et al. A spatial-temporal QoS prediction approach for time-aware web service recommendation. *ACM Trans Web* 10(1) (2016), 701–725.
15. X. Wu, Y. Fan, J. Zhang, et al. QF-RNN: QI-matrix factorization based RNN for time-aware service recommendation. In: *2019 IEEE International Conference on Services Computing (SCC)*, Milan, Italy 19(2) (2019), 202–209.
16. Z. Yang, B. Wu, K. Zheng, et al. A survey of collaborative filtering-based recommender systems for mobile internet applications. *IEEE Access* 4(1) (2016), 3273–3287.
17. B. Yang, Y. Lei, J. Liu, W. Li. Social collaborative filtering by trust. *IEEE Trans Pattern Anal Mach Intell* 39(8) (2017), 1633–1647.
18. A. Abbasi, H. Chen, S. Thoms, T. Fu. Affect analysis of web forums and blogs using correlation ensembles. *IEEE Trans Knowl Data Eng* 20(9) (2008b), 1168–1180.



Zhijie Li born in Changsha City, Hunan Province. He graduated with a Master's degree from the South China University of Technology. Currently, he is a lecturer at the Guangdong Mechanical & Electrical Polytechnic. Research interests include network communication technology and information security technology. E-mail: 2006010012@gdmec.edu.cn

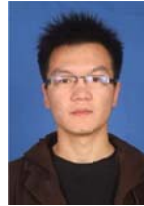

Jincheng Hu was born in Nantong, Jiangsu, China, in 1985. He received the B.S. degree from Southeast University, Nanjing, Jiangsu, China, in 2008 and the M.S. degree from Fudan University, Shanghai, China, in 2011. He is currently pursuing the Ph.D. degree in electronic business at the Shanghai University of Finance and Economics, Shanghai, China. His research interests include blockchain, deep learning, image processing and big data analysis. E-mail: hujincheng8888@126.com

